

Office of the City Manager

CONSENT CALENDAR  
April 26, 2005

To: Honorable Mayor and  
Members of the City Council

From: Phil Kamlarz, City Manager

Subject: Contract Extension: Community Conservation Center

RECOMMENDATION

Adopt a Resolution authorizing the City Manager to extend the Community Conservation Center (CCC) contract for one year, from July 1, 2005 through June 30, 2006 at a cost not to exceed \$238,000.

FISCAL IMPACTS OF RECOMMENDATION

Funds are currently budgeted for this ongoing expense in the Refuse Fund (Budget Code #820-5607-432.30-38). Current annual expenses for the CCC contract are approximately \$231,000 (see Attachment B). This contract rate was set in 2000, and the current rate reflects a much needed cost-of-living adjustment of roughly 2.9% (average Consumer Price Index from 2000 to 2004).

CURRENT SITUATION AND ITS EFFECTS

The City operates a Solid Waste Transfer Station at 1201 Second Street, where urban discards are received and loaded into trailers for hauling to the Vasco Road Landfill in Livermore, California. Organics are hauled away for composting and recyclables are diverted to the Recycling Facility.

CCC is a long-time Berkeley non-profit working with the Public Works Department that processes all of the City of Berkeley's residential and commercial recyclables. CCC operates a buy-back and drop-off recycling program and furnishes all management, supervision, labor, maintenance, repair, equipment, and supplies necessary to provide these services. Commingled materials (including tin and aluminum cans and aluminum foil, mixed color glass, dry clean newspaper, selected high-grade paper and corrugated cardboard) are collected by various organizations and processed at CCC's recycling center. Processing includes receipt of commingled materials and separating, grading, baling, storing, marketing and transporting recyclable materials to their final destination all over the world.

CCC's total revenues from sales of recyclables are approximately \$2,770,000, which is more than 75% of their total revenue. CCC pays out almost \$1 million annually to citizens of Berkeley who sell their recyclables at the Buyback. In addition to the annual payment to City of Berkeley for recyclables of over \$130,000, an annual payment is also made to the Ecology Center (community agency that manages the Curbside Residential Recycling Program) of approximately \$945,000

for recyclables. Attachment C shows additional information about the truck and maintenance costs incurred by CCC.

Without the services currently provided by CCC, Solid Waste Management Division staff would have to assume operation of the facility or transport the recycled materials to another facility (the closest facilities are in Oakland and Richmond and it is uncertain if these operations could assume City of Berkeley's tonnage). If City of Berkeley assumed this operation, the Solid Waste Management Division would also suffer loss of revenue on sales of recyclables.

In the industry, recycling services contracts are generally written for extended periods (eight to twenty-year contracts are common in this discipline) to allow for effective equipment cost amortization and program planning, implementation and active monitoring. The City has maintained an agreement for residential and commercial recyclables with CCC since 1993 (this was amended in February, 2000. CCC handles an annual average of 19,000 tons of recyclables. The current contract expires July 1, 2005.

The Solid Waste Management Division is updating the Solid Waste Master Plan (SWMP). It is scheduled for review by the Solid Waste Management Commission this spring and completion this fall. In light of Alameda County's mandate that recycling be increased to 75% by 2010, it is very likely that SWMP recommendations may greatly impact the strategy used by recycling services. It is very likely that SWMP recommendations may greatly impact the strategy used for recycling services. In the interim period, it is most prudent to maintain existing contracts until SWMP recommendations are available, and base competitive bidding strategies on new opportunities. A one-year extension may give staff and the Solid Waste Management Commission an opportunity to analyze SWMP recommendations, provide an analysis of recycling options to maximize services in a cost-effective manner, present these to Council for policy direction, and proceed with an implementation process to ensure the best result.

#### RATIONALE FOR RECOMMENDATION

Allowing results of the SWMP to shape recycling contracting opportunities is more prudent than competitive bidding at this time based on current standards and missing opportunities to restructure contracts to more appropriately match the current and future needs of the City.

#### ALTERNATIVE ACTIONS CONSIDERED

Effectively bidding the residential recycling program contract is a time-consuming alternative that may not make the best use of the City of Berkeley's financial or human resources.

CONTACT PERSON

Rene Cardinaux, Director of Public Works.....981-6300  
Tom Farrell, Solid Waste and Recycling Manager.....981-6359

Approved:

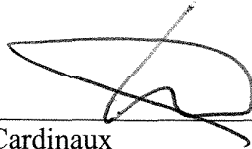

\_\_\_\_\_  
Rene Cardinaux  
Director of Public Works

- 1: Attachment A—Resolution
- 2: Attachment B—Proposed 2006 Community Conservation Center Budget
- 3: Attachment C—Community Conservation Center Trucking and Maintenance Expenses

RESOLUTION NO.

-N.S.

AUTHORIZING THE CITY MANAGER TO EXTEND THE COMMUNITY CONSERVATION CENTER (CCC) CONTRACT FOR ONE YEAR, FROM JULY 1, 2005 THROUGH JUNE 30, 2006 AT A COST NOT TO EXCEED \$238,000

WHEREAS, funds are currently budgeted for this ongoing expense in the Refuse Fund; and

WHEREAS, CCC is a long-time Berkeley non-profit working with the Public Works Department that processes all of the City of Berkeley's residential and commercial recyclables along with commingled materials that are collected by various organizations and processed at the CCC recycling center; and

WHEREAS, the Solid Waste Management Division is updating the City's Solid Waste Master Plan (SWMP) that is scheduled for review by the Solid Waste Management Commission this spring and completion this fall; and

WHEREAS, it is very likely that SWMP recommendations may greatly impact the strategy used for recycling services so in the interim, it is most prudent to maintain existing contracts until SWMP recommendations are available, and base future competitive bidding strategies on new opportunities.

BE IT FURTHER RESOLVED that the Council of the City of Berkeley authorizes the City Manager to execute a one-year contract extension with the Community Conservation Center in an amount not to exceed \$238,000 (Budget Code #820-5607-432.30-38). A record signature copy of said agreement to be on file in the Office of the City Clerk.

PROPOSED 2006 COMMUNITY CONSERVATION CENTER BUDGET

Attachment B

	FY 2006
Sorting Fees	180,000
Disposal Fees	58,000
<b>TOTAL</b>	<b>238,000</b>

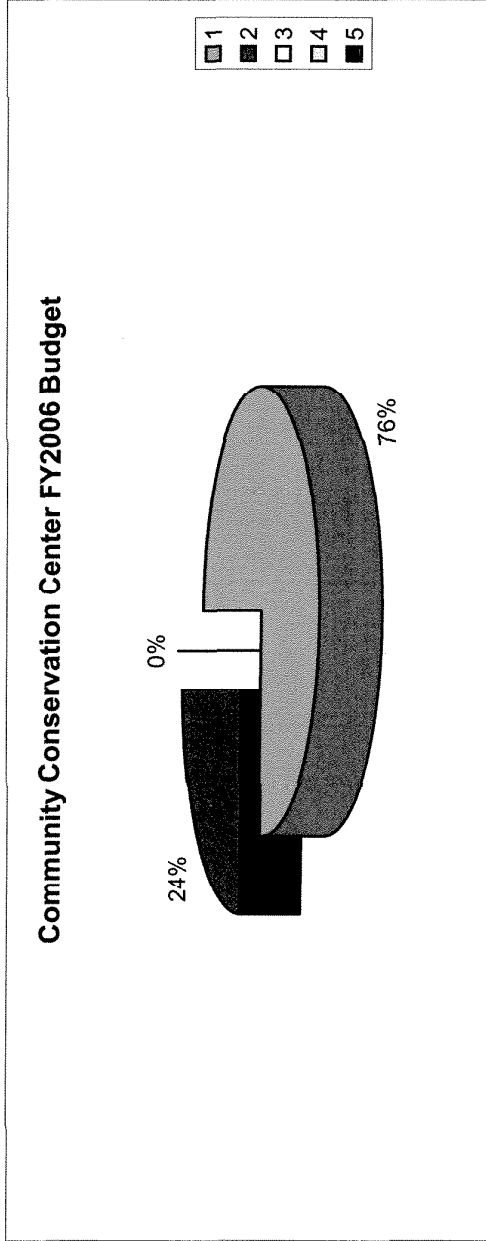

City of Berkeley pays Community Conservation Center fees to sort and dispose of recycling.

**COMMUNITY CONSERVATION CENTERS, INC.**  
**FY 2004-05 Budget Compared to Estimated Actual at 12/31/04**

	<b>FY 2003-04</b>	<b>FY 2004-05</b>
	<b>Actual Expense</b>	<b>Approved Budget</b>
<b>TRUCKING EXPENSES:</b>		
Roll-off truck parts, tires	\$9,000	\$9,000
International parts, tires	\$9,202	\$7,500
Truck Maint./Replacements	\$10,000	\$17,263
License/fees	\$5,500	\$6,500
Truck Fuel	\$15,600	\$14,053
Insurance	\$12,118	\$12,723
Glass Trucking - SEE Cost of Sales		
<b>Subtotal: Trucking Expenses</b>	<b>\$61,419</b>	<b>\$67,039</b>
<b>MAINTENANCE:</b>		
Small equipment	\$8,132	\$5,000
Container line		\$6,500
Paper sorter		\$3,500
Baler Maintenance	\$19,192	\$14,466
Loader Maintenance	\$9,717	\$12,549
Scale maintenance	\$4,073	\$4,788
Forklift Maintenance	\$24,870	\$16,004
Equipment Rentals	\$9,986	\$7,500
Other	\$1,000	\$1,000
<b>Subtotal: Lease/Maintenance</b>	<b>\$74,180</b>	<b>\$71,307</b>