

January, 2006
City of Berkeley Bike Rack Specifications and Installation Standards

Rack Style

- Racks installed on City ROW shall be inverted U style, constructed of at least 2 3/8" O.D. Schedule 40 round pipe or 2"x2"x.188" wall square pipe, galvanized or stainless steel.
- Racks shall be 32" to 36" tall by 24" to 30" wide.
- Flanges for surface mounted racks must be 3/8" thick and drilled with 9/16" holes to admit 1/2" fasteners.
- For installation of multiple racks side-by-side, Rail Mounted Inverted U racks can be used.
- The capacity of each inverted U rack is two bicycles, locked parallel to the rack.

Mounting

- Racks installed on concrete should be surface flange mount style.
- Fasteners must be 1/2" x 3" mushroom head stainless steel Powers spike, or equivalent (manufacturer information attached)

Placement, Orientation and Clearance in the public right-of-way:

- Inverted U racks are designed to accommodate bikes parked parallel to the rack, resting against both upright members.
- Generally, racks should be installed parallel to the curb so as to minimize needlessly taking up sidewalk space.
- Where there is sufficient sidewalk width or racks are placed in the roadway, racks can be placed perpendicular to the curb.
- Multiple individual racks installed parallel to the curb, end to end, must be separated by a minimum of 48". 60" is preferred.
- Multiple racks placed perpendicular to the curb, side-by-side, must be separated by a minimum of 30". 36" is preferred.
- Racks must be oriented such that they do not interfere with pedestrian path of travel on the sidewalk, yet are not so close to the curb that the rack can be inadvertently hit by the overhang of a car as it parks.
- Check for any sidewalk utility boxes (such as water or sewer) that need to be accessed.
- Make sure that the racks posts are not in conflict with rain water leaders or drain lines under the sidewalk
- Do not locate racks where they interfere with exiting vehicles parked at the curb
- There should be a minimum of 5 1/2' clear for pedestrian right-of-way outside the footprint; 7' in areas of heavy pedestrian traffic.
- Rack should be located a minimum of:
 - **18" from:** the curb
 - **30" from:** light pole
 - **3' from:** Newspaper Racks, US Mailbox, Light Pole, Sign Pole, Bus Shelter, Driveway, Surface Hardware (PG&E, Cable grates, etc.), Street Furniture, Standpipes, Bus Benches, Trash Cans, Other sidewalk obstructions
 - **4' from:** AC Transit Red Zone, Loading Zone, Blue Zone (disabled parking), Curb/Curb ramps, Crosswalk, BART entrance
- **5' from:** Fire Hydrant



Manager of Engineering

1/23/06

Date

City of Berkeley Bicycle Rack Specifications

Single Inverted U

January 2006

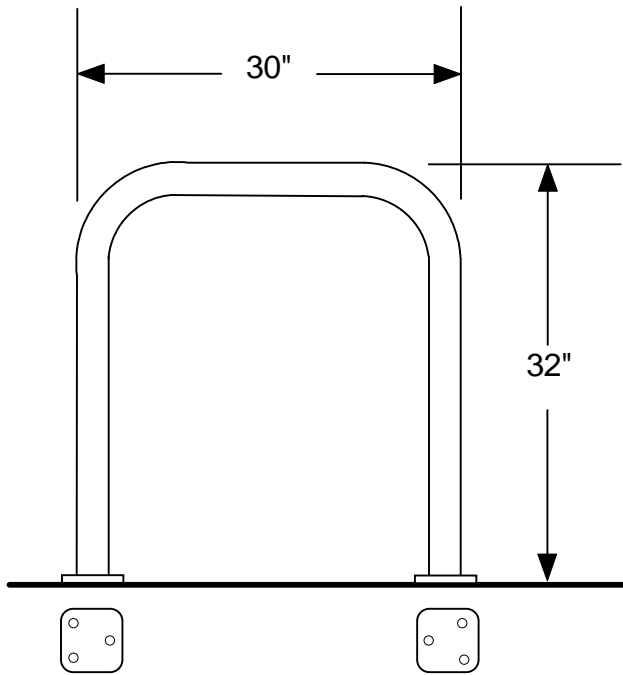

Surface Mounted Single Inverted U

Height: 32"

Width: 30"

Flanges: 5" x 6" x 3/8"

Mounting Holes: (6) 9/16" dia.

Square Tube: 2" x 2" x .188" wall

Finish: Hot-dipped Galvanized

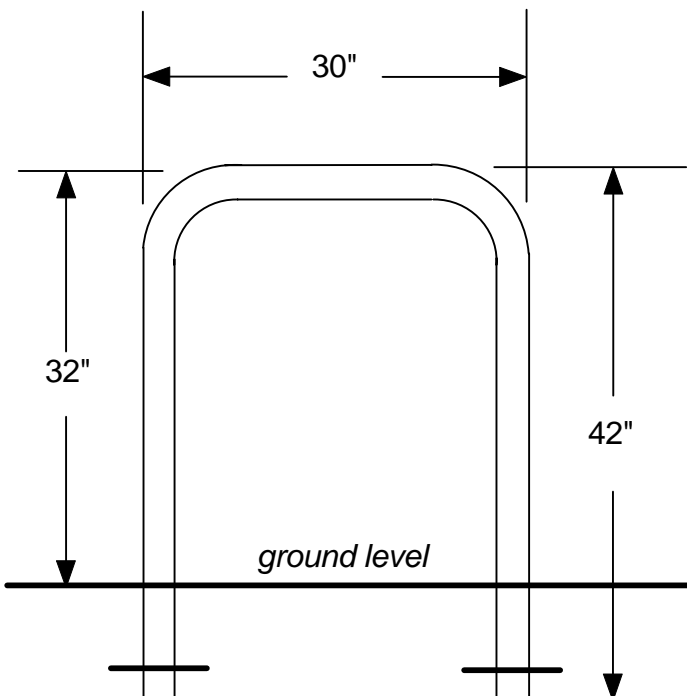

Sub-Surface Mounted Single Inverted U

Height: 42"

Width: 30"

Square Tube: 2" x 2" x .188" wall

Finish: Hot-dipped Galvanized

City of Berkeley Bicycle Rack Specifications Rail Mounted Inverted U

January 2006

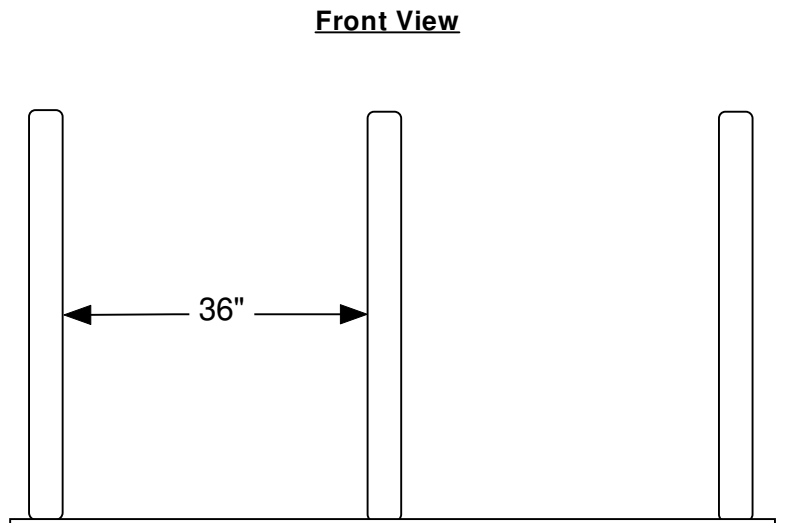
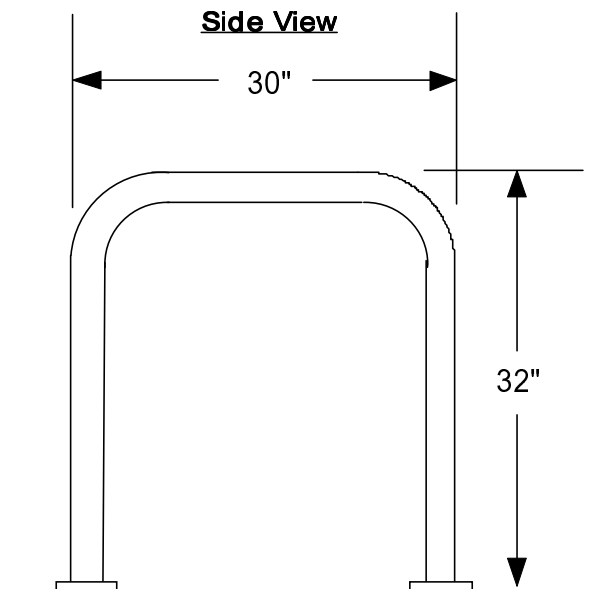

Top Views

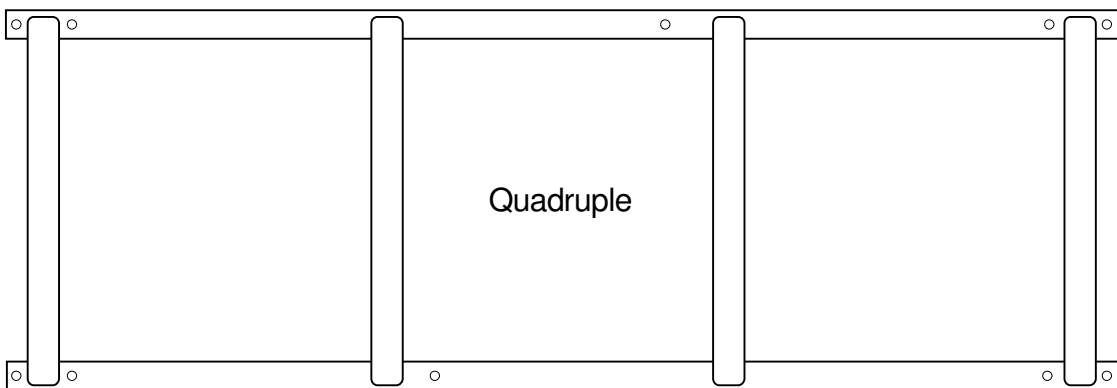
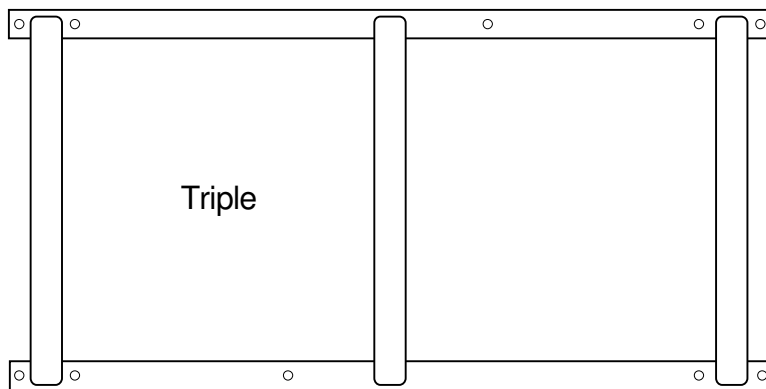

City of Berkeley Bike Rack Specifications and Installation Standards

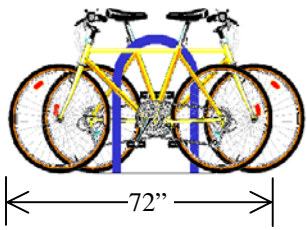

Rack Capacity is 2 bicycles.
Bikes are parked parallel to rack.
Typical bike is 72" in length.

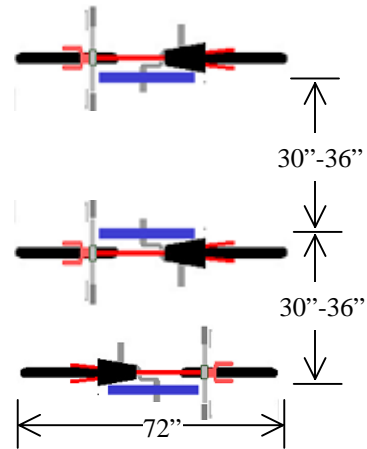

36" spacing between side-by-side racks is preferred, minimum 30"

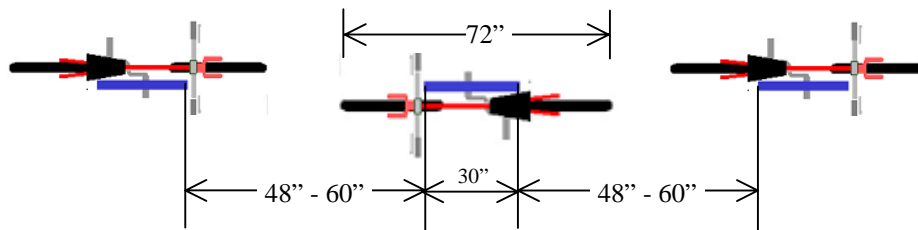

End-to-end racks shall be placed 48" to 60" apart.

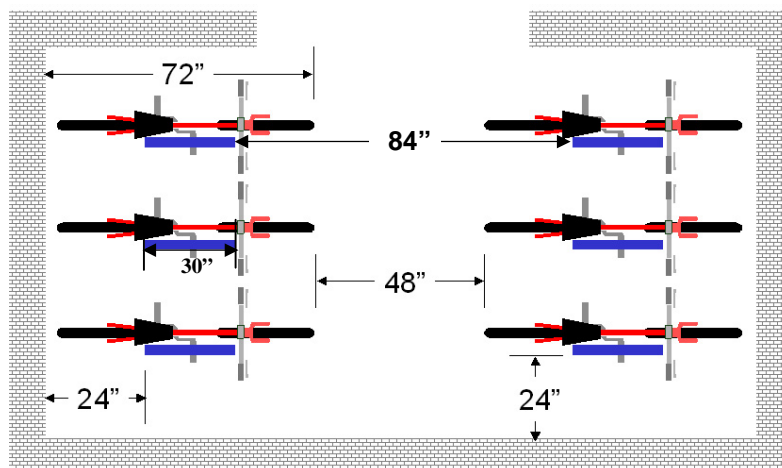

Minimum 24" of clearance from rack to wall or fence. 84" aisles between 30" racks in enclosures, to leave 48" between bikes.

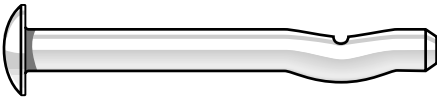

SPIKE®

BASE MATERIAL

Concrete, Block, Brick, Stone

SIZE RANGE

3/16" x 1" to 1/2" x 6-1/2"

ANCHOR MATERIAL

Carbon Steel and Type 316 Stainless Steel

PRODUCT DESCRIPTION

The SPIKE is a patented, one-piece, vibration resistant anchor for use in concrete, block, brick, or stone. Several head styles and anchor materials are available. Some sizes are tamperproof and others are removable.

The pre-expanded mechanism of the SPIKE anchor is activated as the anchor is driven into the drilled hole creating a spring type compression force against the walls of the hole.

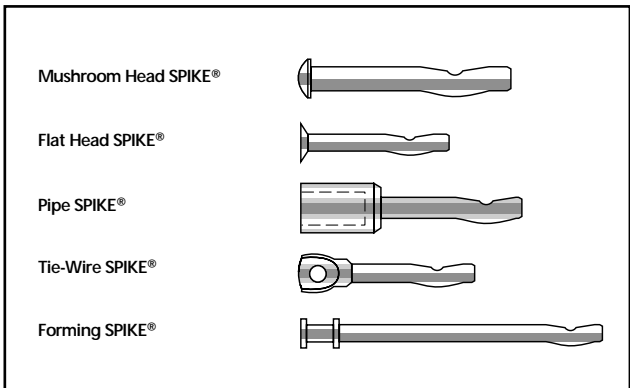

Once seated at the required embedment, residual spring force developed in the expansion mechanism provides three compression forces at the bottom of the anchor hole. When a vibratory load is applied to some other anchor types, the area of the base material around the expansion mechanism may experience localized pulverization at the point of contact. The SPIKE has been designed to overcome this problem. When subjected to vibratory loads, the SPIKE will expand due to the residual spring action of the expansion mechanism if localized pulverization occurs.

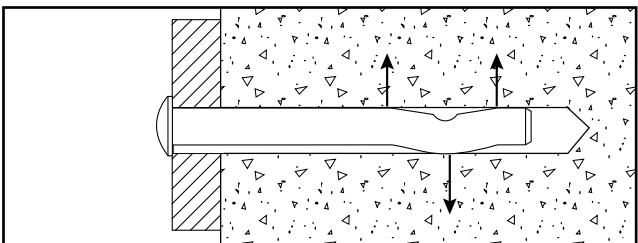

SPIKE is a proprietary anchor that can be used in applications that traditionally have been addressed by wedge and sleeve type expansion anchors, drop-in

style anchors and concrete screws. Use of the SPIKE anchor reduces installation time. Since the anchor is pre-expanded, there is no secondary tightening or expanding operation required which greatly reduces the overall cost of an anchor installation.

INSTALLATION PROCEDURES

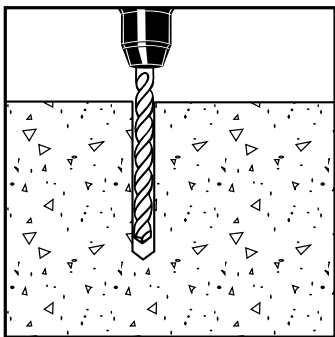

Drill a hole into the base material to a depth of at least 1/2" deeper than the embedment required. The tolerances of the drill bit used should meet the requirements of ANSI Standard B212.15. Blow the hole clean of dust and other material.

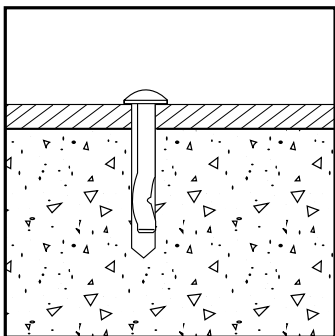

Where a fixture is used, drive the anchor through the fixture into the anchor hole until the head is firmly seated against the fixture. Be sure the anchor is driven to the required embedment depth. The Tie-Wire and Pipe SPIKE versions should be driven in until the head is seated against the surface of the base material.

ANCHOR SIZES AND STYLES

To select the proper minimum anchor length, determine the embedment depth required to obtain the desired load capacity. Then add the thickness of the fixture, including any spacers or shims, to the embedment depth. On the Tie-Wire and Pipe SPIKE versions, no fixture is used. These anchors should be driven in until the head is seated against the surface of the base material.